

## Technology Offer

## Broad-spectrum vector-based antiviral and potential live vaccine

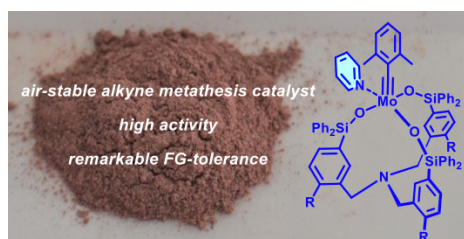

Prof. Alois Fürstner and co-workers at Max Planck Institut für Kohlenforschung developed a new class of molybdenum alkydine catalysts equipped with tripodal silanolate ligands which mark a significant milestone in the field of alkyne metathesis. Their improved stability, functional group tolerance, and ease of synthesis position them as valuable tools for researchers and industry professionals alike, promising to expand the scope of alkyne metathesis applications in organic synthesis and materials science.

## Background

During the past two decades, alkyne metathesis has arguably evolved from a curiosity to a method of strategy level status in material science and small molecule synthesis. Notwithstanding the high level of sophistication in the field, improved user-friendliness is desirable; only if the best catalysts are easy to handle are they going to be routinely used. Thus the development of efficient and stable catalysts for this reaction is crucial for enabling more sustainable and versatile synthetic pathways.

## Technology

A new ventilation system has been designed to overcome the aforementioned shortcomings. The miniaturized system of spherical shape (cf. Fig. 1) has diameter of  $\approx 7$  cm and a typical mass of 50g. Its housing hosts a central unit, radial blowers (1), and is equipped with an on/off switch and interface functions. Besides plug-in connectors, also Blue Tooth connections are available. In Fig. 1, (2) marks the air inlet, while (3) denotes the air outlet where a respiratory mask and a filter can be attached. The whole ventilation duct between (2) and (3) is bidirectional, and this construction allows a low dead volume. In case of increased pressure during exhalation phases, the valves (4) automatically open. The sensors (5) are capable of measuring the pressure and flux. Together with the steering unit (6), a steering control of the radial blowers can be established.

The power consumption of the system is around 12 W. Assuming the ventilation system is driven by a rechargeable power-pack with typically 10.000 mAh and a voltage of 12V, this translates to an operation time of  $\approx 10$  h.

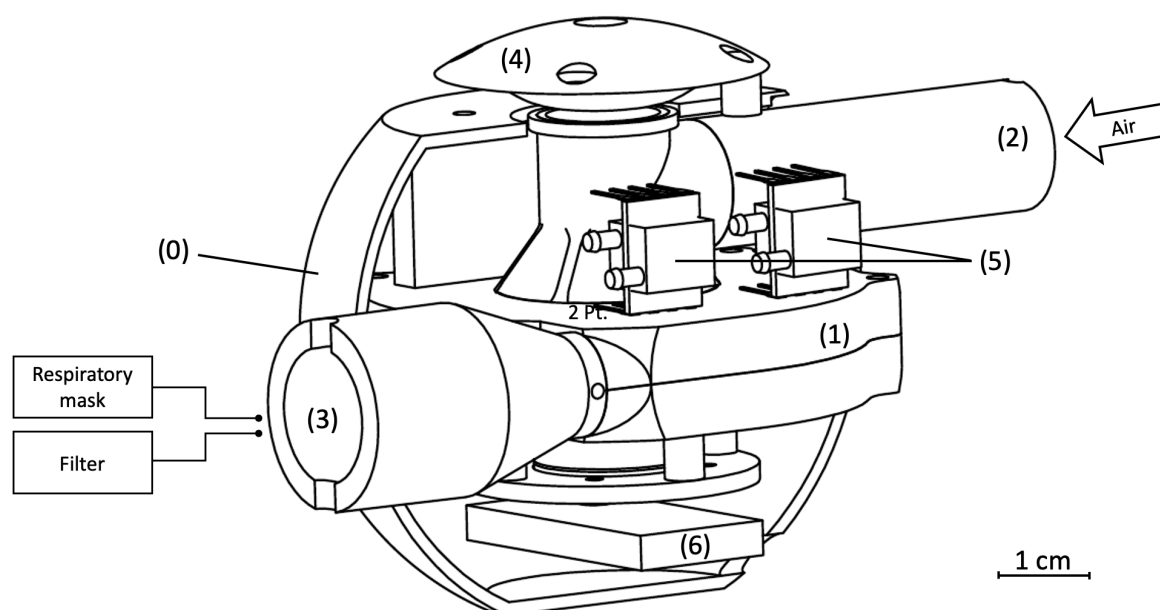



Fig. 1: 3D cut of the ventilation system. (0) housing, (1) radial blowers, (2) air inlet, (3) air outlet, (4) valves for the case of increased pressure during exhalation phases, (5) sensors and (6) steering unit.

### Advantages

- Low-budget
- Low power consumption
- Lightweight
- Easy to handle
- Open system without physical safety issues
- Low dead volume
- System/radiation blowers: Non-blocking, no safety valves
- Relatively small: diameter 150 mm, length 1 m (energy-dispersive spectrometer:  $\approx 1 \text{ m}^3$ ).

### Applications

- Patients lacking access to a health care system
- Mobile groups/vehicles
- Hospitals in regions with damaged or “weak” infrastructure (leading to frequent blackouts)
- Standby for high standard hospitals in case of pandemic

### Patent Information

DPMA, PCT

### Contact

**Dr. Lars Cuypers**  
Senior Patent- & License Manager  
Chemist  
eMail: [cuyper@max-planck-innovation.de](mailto:cuyper@max-planck-innovation.de)